

General Assembly Meeting

10h – 12:30h

12 November 2013

Annual **BAZAAR** Annuel



NATO Charity Bazaar
www.natocharitybazaar.org —ASBL—

SUNDAY - DIMANCHE
17 NOV. 2013 • 10.30 - 16.30

NATO CAFETERIA DE L'OTAN
Boulevard Léopold III - Brussels 1110 Bruxelles

Proceeds in aid of Belgian and International Charities
Au profit d'œuvres caritatives Belges et Internationales



OPEN to NATO and Shape id holders. • OUVERT à tous les membres détenteurs d'un laissez-passer OTAN et Shape.



NATO Charity Bazaar

www.natocharitybazaar.org

—ASBL—

ASBL: 874.358.592 | Avenue Victor Gilsoul 1 - 1200 Brussels - Belgium



Agenda

- **Welcome** by Jimmie Bradshaw
- **Welcome and Farewells to Members**
 - **VOTE: Approval of minutes from the GM at 22th October 2013**
- **Bazaar Update** by Jette Holm Kristensen
- **Opening Ceremony** by Jimmie Bradshaw
- **Tombola Update** by Carla Bucalossi Quatrini

Coffee Break (15 minutes)

- **Restaurant Update** by Christina Arvanitaki
- **Invitation Lists and Passes** by Beckie Metelko
- **Sponsorship & Event Update** by Dionysia Leolei
- **Treasurer Update** by Alessandra Bertozzi
- **Donation Ceremony** by Jimmie Bradshaw
- **Fundraising** by Jimmie Bradshaw & Karen Kiærskou
- **Any other Business and Closing** by Jimmie Bradshaw

NATO Charity Bazaar



Welcome

Jimmie Bradshaw - President

- Welcome
- Approval of minutes



NATO Charity Bazaar

www.natocharitybazaar.org

— ASBL —



Welcome to Members

Jimmie Bradshaw - President

- **Czech Republic - 2nd ANR - Ludmila Nováková**
- **Estonia - ANR - Leida Nimps**

NATO Charity Bazaar

www.natocharitybazaar.org

— ASBL —



Farewell to Members

Jimmie Bradshaw - President

- **Czech Republic – 2nd ANR – Hana Sklenářová**





FINAL Bazaar Instructions

Jette Holm Kristensen - Bazaar Coordinator

- **Final Instructions & Time Tables**
- **Saturday and Sunday Agendas**
- **Reminders**
- **Stage Schedule (draft)**
- **Trash Dealing & Clean Up**
- **Thank you NATO Staff**
- **Bazaar After Sale**

NATO Charity Bazaar



FINAL Bazaar Instructions

Jette Holm Kristensen - Bazaar Coordinator

- Final Instructions
- Reminders
- Time Tables for Saturday & Sunday
- Key Contact Numbers

Please read them carefully 😊

NATO Charity Bazaar

www.natocharitybazaar.org

— ASBL —

Final Instructions

- Food/drink is only allowed in the International Restaurant area. You are still free to sell unopened or wrapped bottles/food from your National Stands.
- The whole area of the Bazaar is Non-Smoking. Ashtrays are provided outside the building at all regular entrance points.
- Nations are allocated a number of tables. Your allotted tables will be placed in your assigned space. You are responsible for assembling and dismantling the tables. Make sure that your volunteers bring an adjustable wrench or a socket wrench size: 13, 14 and 17 to assemble tables.
- On Sunday, tables and chairs must be dismantled, put in the designated place, and your area must be cleaned.
- NATO is open for “business as usual” on Monday morning. Each is expected to leave the NATO premises in exactly the same state as we normally find it. Therefore, each nation is asked to fold boxes and dispose of their rubbish/waste in the designated containers. We recommend that you bring a vacuum cleaner and a broom for cleaning up your area.
- The NCB Board will have an information desk in front of the Luns Theatre in the Press Hall staffed by the NATO International Club (NIC).
- No food, drink or unaccompanied children will be allowed in the Luns Theatre where the Tombola will take place.

NATO Charity Bazaar

Reminders

- **ACCESS TO NATO:** The following people will have access to the Bazaar:
 - NATO Pass which grant access to the NATO compound and Staff Centre as well as SHAPE and NCIA (The Hague) exchangeable pass holders and their immediate family members (spouse, father, mother, son and daughter).
 - Those holding a valid NCB VIP, GUEST or HELPER Pass obtained in advance through the NCB Guest Coordinator.
 - People delivering goods on Saturday and or Sunday will have access as long as their name and information was submitted in advance to the Guest Coordinator.
 - Children under the age of 12 accompanied by an adult holding a valid pass do not require a pass.
 - The names and information of all approved musicians and entertainers must be submitted in advance to the guest coordinator. The form can be found on the NCB website.

NOTE! The absolute deadline for any and all pass requests is November 8th 2013.

NATO Charity Bazaar

Reminders

- **HELPERS:** Helpers will have access by car through Gate Z. Guests must park their car in the Guest Car Park and enter on foot through the main entrance.
- **NATIONAL STAND SPACE:** When you arrive on Saturday, your National Stand space will be “marked” by the placement of the tables. The Fire Inspector and the Bazaar Coordinator will do a walk through on Saturday beginning at 12h. If a stand is blocking an entrance or some other walkway needed for fire safety, the stand must be modified to meet all fire safety requirements.
- **NAME PLATE:** Each nation will be provided a name plate showing the country’s name and national flag. The name plate will be hung above the stand and must be returned when the Bazaar is over. Only name plates can be hung from the ceiling.
- **DECORATIONS:** Nations are free to decorate their stands as they wish, but there are to be no nails, tacks or glue on the walls, and no staples or other damaging materials on the tables. Free-standing frames are allowed if there is space for it, but please aware - it can be very crowded.
- **FOOD ON SATURDAY:** There will be the opportunity to purchase lunch as well as something to drink on Saturday at the International Restaurant where **15** nations will sell food and/or drink.
- **SELLING ON SATURDAY:** Each nation may decide whether they wish to sell items on Saturday or not.

NATO Charity Bazaar



TIMETABLES

Timetable Saturday 16 November:

- 08.00:** Set-up of all stands
- 09.00 to 11.00:** Handing in of Tombola prizes at Luns Theatre
- 11.00:** Opening Ceremony Rehearsal
- 12.00:** Walk-through with Fire/Facilities
- 14.00:** Closing of the Restaurant area
- 16.30:** Closing of the whole Bazaar area. (**Note!** If you are finished before 16.30, it is your own responsibility to ensure the security of your stand until the area is closed).

Timetable Sunday 17 November:

- 08.00:** Opening of the Bazaar area
- 09.15:** Photo session in front of the stage
 - Note!** All National & Assistant National Representatives in place no **later than 9:10h**
- 09.45:** Opening Ceremony at the podium (in front of the stage in the Cafeteria)
- 10.00:** **Bazaar Officially Open to Public**
- 10.15:** Patrons preview International Restaurant
- 11.00:** Patrons preview National Stands
- 13.00:** Tombola Ticket Sales ends
- 14.00:** Tombola starts
- 16.00:** Return of nation's name plates to NCB Information Desk.
- 16.30:** Closing of the Bazaar. (**Note!** All stands need to follow the clean up procedure and be checked out by the Bazaar Coordinators before they can leave).

KEY CONTACT NUMBERS

Bazaar 2013

Have a great time.

Together we're raising money to support wonderful Belgian and International Charities.

KEY CONTACT NUMBERS:

Should you have any questions or problems during the Bazaar, please contact the appropriate member of the NCB Board by GSM or go to the NCB Information Desk in front of the Luns Theatre in the Press Hall. Help yourself by adding these phone numbers to your contacts in your telephone ☺

Vice-president & Bazaar

- Jette Holm Kristensen: 0498 03 66 01

Assistant Bazaar

- Linda Aziz Skou: 0473 64 43 79

Tombola

- Carla Bucalossi Quatrini: 0495 51 23 23

Emergency Calls

- 4000 (all internal phones on the walls)
- 02 707 4000 (from mobile phones)

International Restaurant

- Christina Arvanitaki: 0476 80 56 36

President (only emergencies)

- Jimmie Bradshaw: 0494 66 08 55

Guest Access

- Beckie Metelko: 0484 50 35 83

Treasurer

- Alessandra Foresti: 0488 41 65 95



FINAL Bazaar Instructions

Jette Holm Kristensen - Bazaar Coordinator

2013 Phone Cards



NATO Charity Bazaar

www.natocharitybazaar.org

— ASBL —



Saturday Agenda

- **8:00h** - Set-up of National Stands starts with volunteers from each nation.
- **9:00h-11:00h** - Handing in of Tombola Prizes and ALL tickets at Luns Theatre.
- **11:00h** - Opening Ceremony Rehearsal.
- **12:00h** - Walk through with Fire/Facilities
- **14:00h** - Closing of the Restaurant area.
- **16:30h** - Closing of the whole Bazaar area.

NATO Charity Bazaar



Sunday Agenda

- 8:00h** - Opening of the Bazaar area for **SETUP ONLY**
- 9:15h** - Photo session in the Cafeteria area
Note! All NR + ANR in place **no later than 9:10h.**
- 9:45h** - Opening Ceremony on the Podium in the small Cafeteria.
- 10:00h** - Bazaar Officially Opens to Public
- 10:15h** - Patrons preview of International Restaurant.
- 11:00h** - Patrons preview of National Stands
- 13:00h** - Tombola Ticket sales ends
- 14:00h** - Tombola starts.
- 16:00h** - Return of signs and flags to the information desk.
- 16:30h** - Closing of the Bazaar.

NATO Charity Bazaar



Reminders

Jette Holm Kristensen - Bazaar Coordinator

NO COMMERCIAL VENDORS

Items offered by nations at the Bazaar must be presented on a non-commercial basis. That is, no commercial vendors are allowed to participate as part of a nation's stall.

ALL PROCEEDS GO TO CHARITY

All proceeds (less legitimate overhead costs) must be transferred to the NATO Charity Bazaar ASBL Bank account.

FINAL AUTHORITY

The final authority for all aspects of the Bazaar rests with the President of the NATO Charity Bazaar ASBL in consultation with the appropriate NATO authorities.



NATO Charity Bazaar

REMINDERS

No Material may be attached to
NATO walls or ceiling

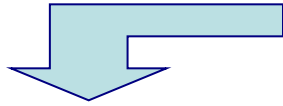

ONLY freestanding
frame or shelving
are allowed

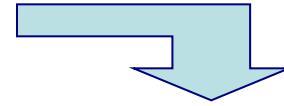

NAME PLATES

Each nation will be provided a name plate showing the nations name and national flag. Please hang your name plate so that it is visible.

NOTE: This is the **ONLY** item that can be hung from the ceiling





When you Arrive on Saturday

Your area will have:

- 1. Tables + Chairs**
- 2. Phone Card (Key Contact Numbers)**
- 3. Name Plates ready to be displayed prominently**
- 4. Two (2) white garbage bags**
- 5. 'Clean Up Check List' with the number of tables you were provided in 2012**
- 6. Floor Plan in A4 + 2013 Tri-folds**

NATO Charity Bazaar

Floor Plan 2013

• NCB Info Table

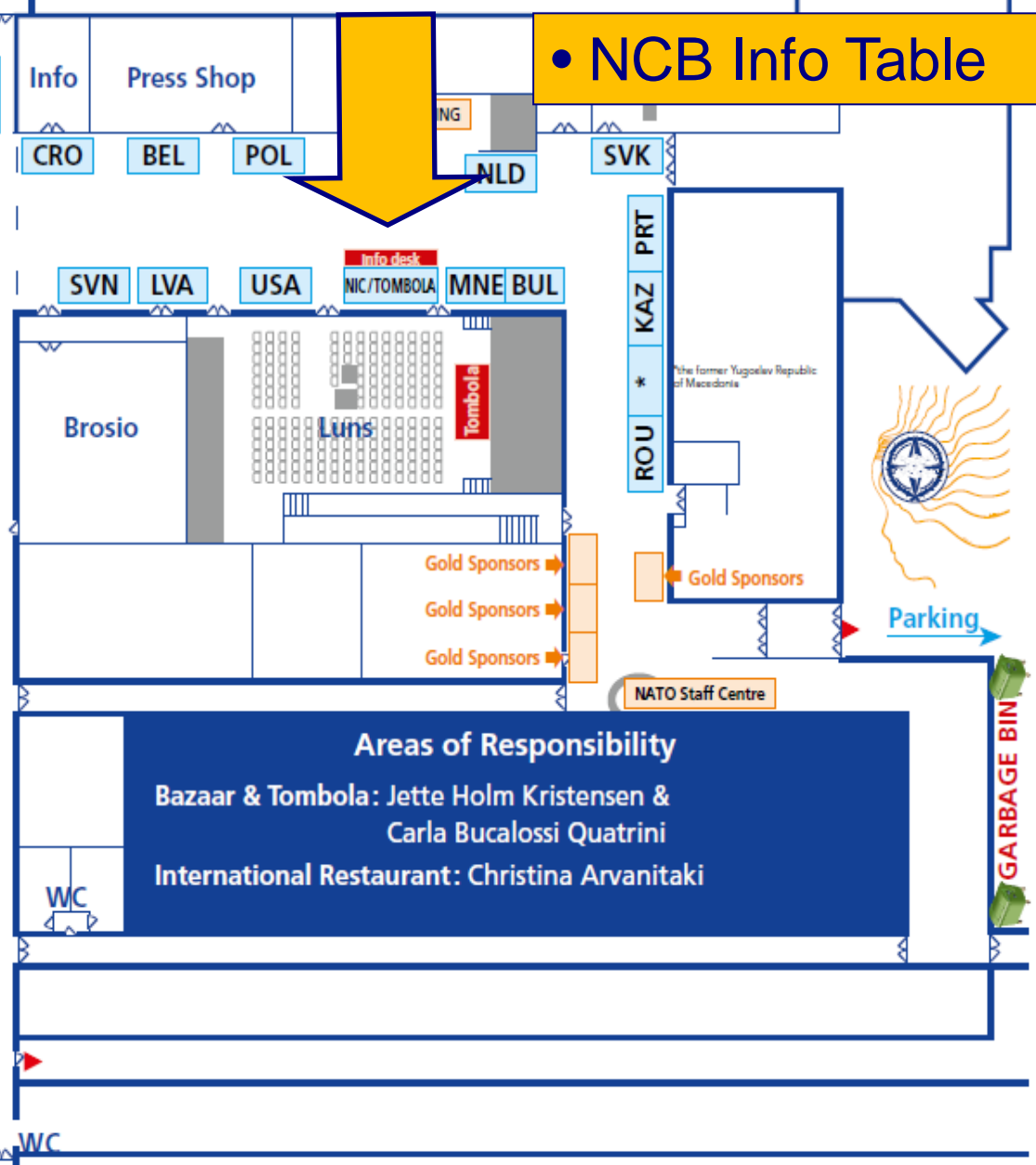
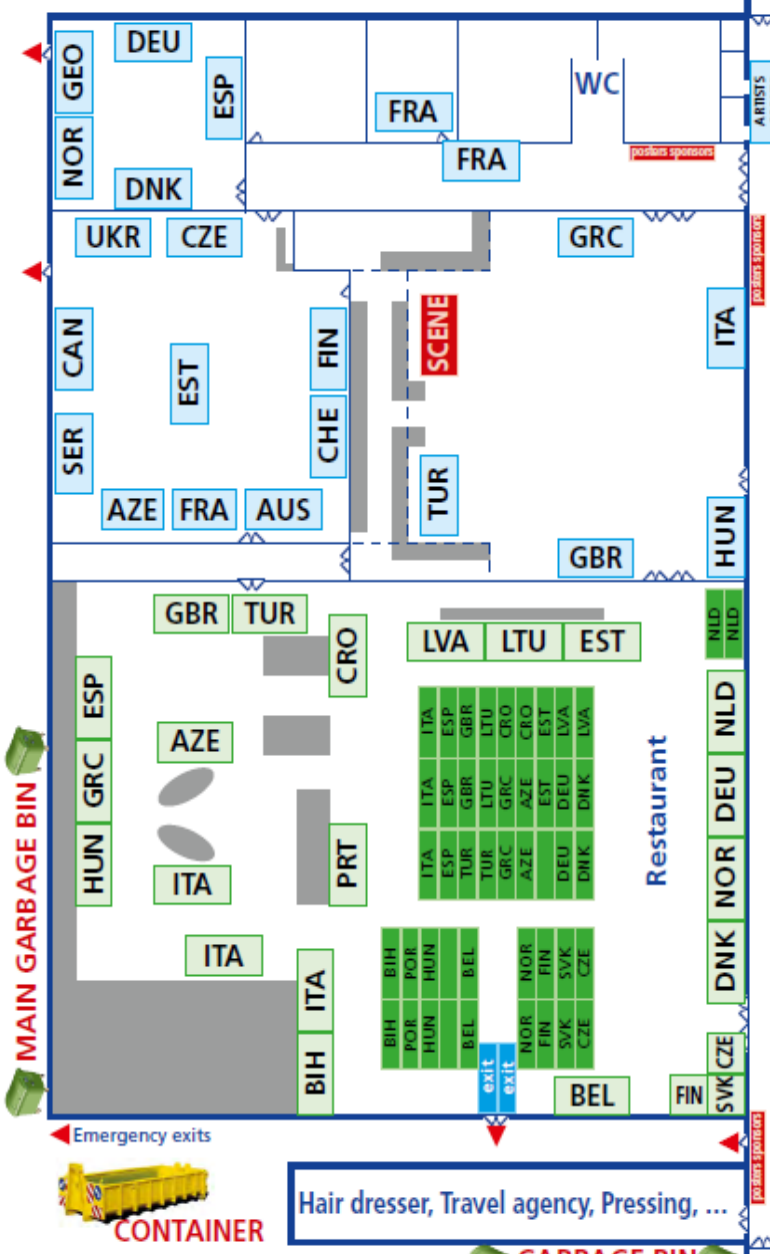

Areas of Responsibility
 Bazaar & Tombola: Jette Holm Kristensen & Carla Bucalossi Quatrini
 International Restaurant: Christina Arvanitaki

* Turkey recognises the Republic of Macedonia with its constitutional name.

NATO Charity Bazaar

Floor Plan 2013

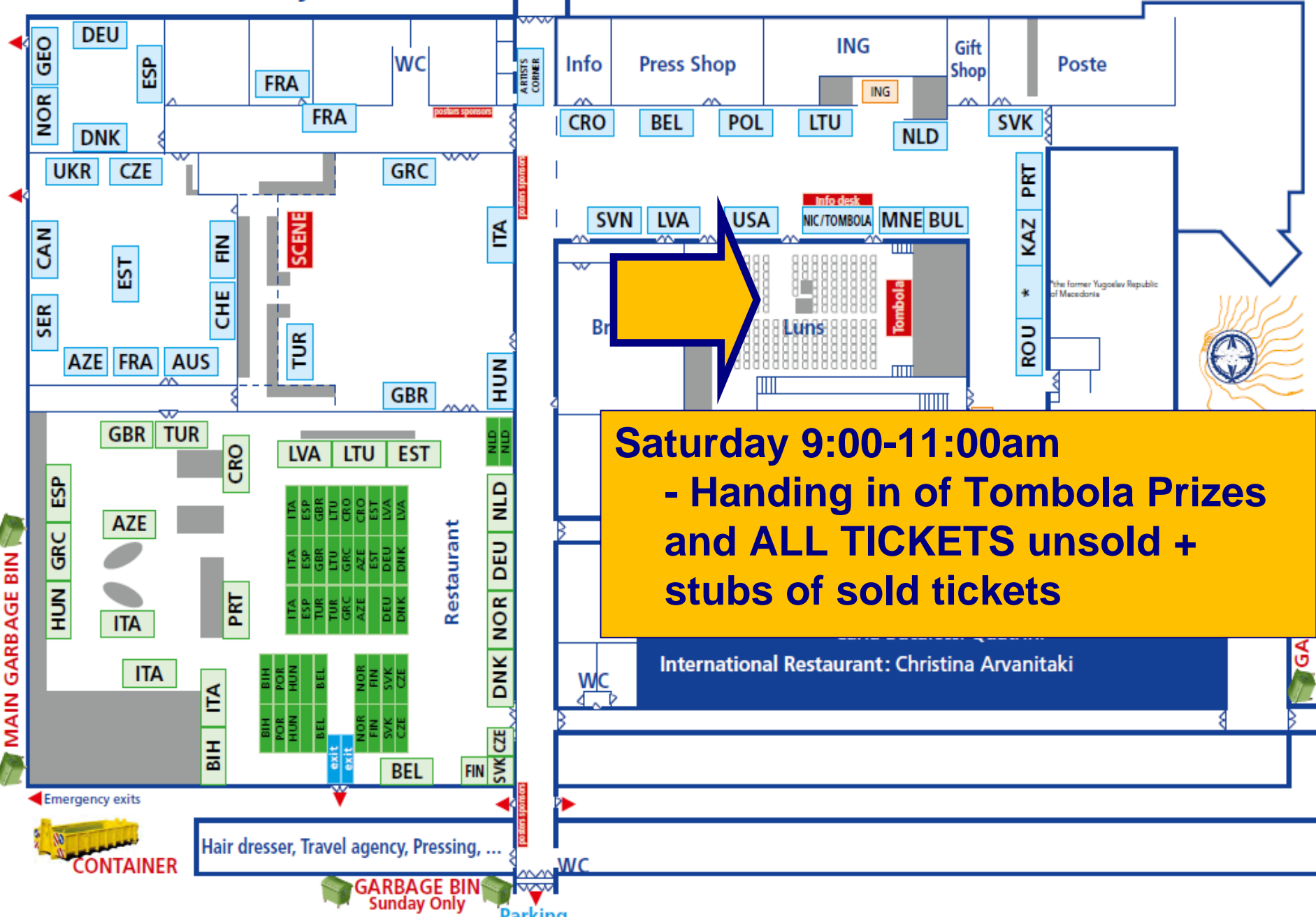

* Turkey recognises the Republic of Macedonia with its constitutional name.

NATO Charity Bazaar

Floor Plan 2013

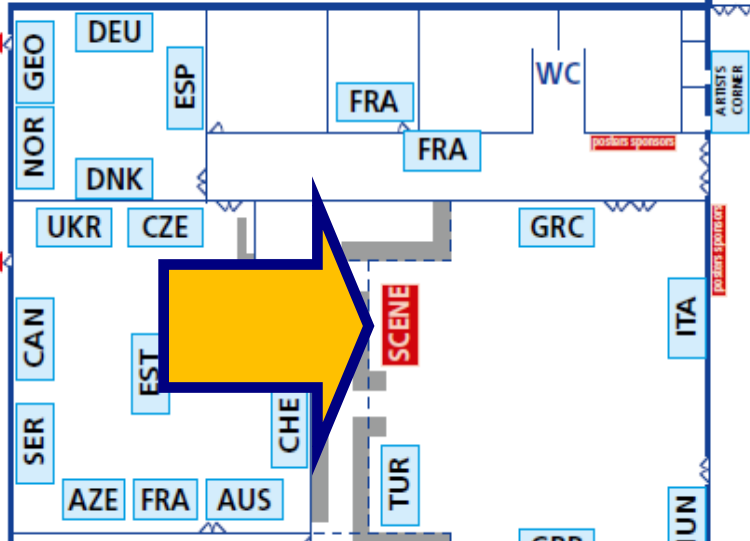

Saturday

- 11:00h Opening Ceremony rehearsal

Sunday

- 9:15h Group Photo
- 9:45h Opening Ceremony

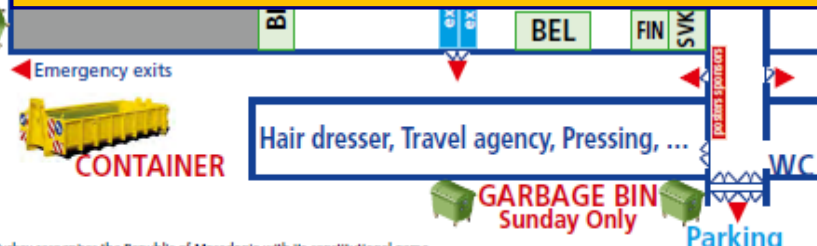

* Turkey recognises the Republic of Macedonia with its constitutional name.



Supplies to bring

- **Extension Cord**
- **Power strip**
- **Broom and dustpan**
- **Tape, pens, string**
- **Small ladder**
- **Rubbish container for your stand**
- **Vacuum**





Stage Schedule Draft

- 09:45 – 10:15 **OPENING CEREMONY**
- 10:45 – 11:00 Ukraine, One singer and two violinists
- 11:15 – 11:30 Estonia Folklore Dancers - *Euroviisud*
- 11:30 – 11:45 Estonian & Belgian Folklore Musicians - *EstBel*
- 11:55 – 12:25 Bulgarian Dancers
- 12:35 – 12:45 Kazakhstan Dancers
- 13:00 – 13:15 Greek Dancing Team from Greek School Brussels
- 13:25 – 13:50 Slovenian Music presented by Belgian Accordion player
- 14:00 – 14:15 Finish Gold Panner, *Jukka Kela*
- 14:30 – 14:45 Italian singer, *Domenico Iaia*
- 15:00 – 15:15 *Rufus' Band* from Portugal
- 15:30 – 16:00 Estonian Band – *Beautiful Fathers*

Dealing with Trash

**A Primer on
disposing of
waste before,
during, and
after the Bazaar**





Blue Bins

Contents: Paper & Cardboard
Boxes





Red Bins

Contents: General Waste
including plastic





Throw your garbage into this huge garbage container

NATO Charity Bazaar

www.natocharitybazaar.org

— ASBL —

NATO Charity Bazaar

Floor Plan 2013

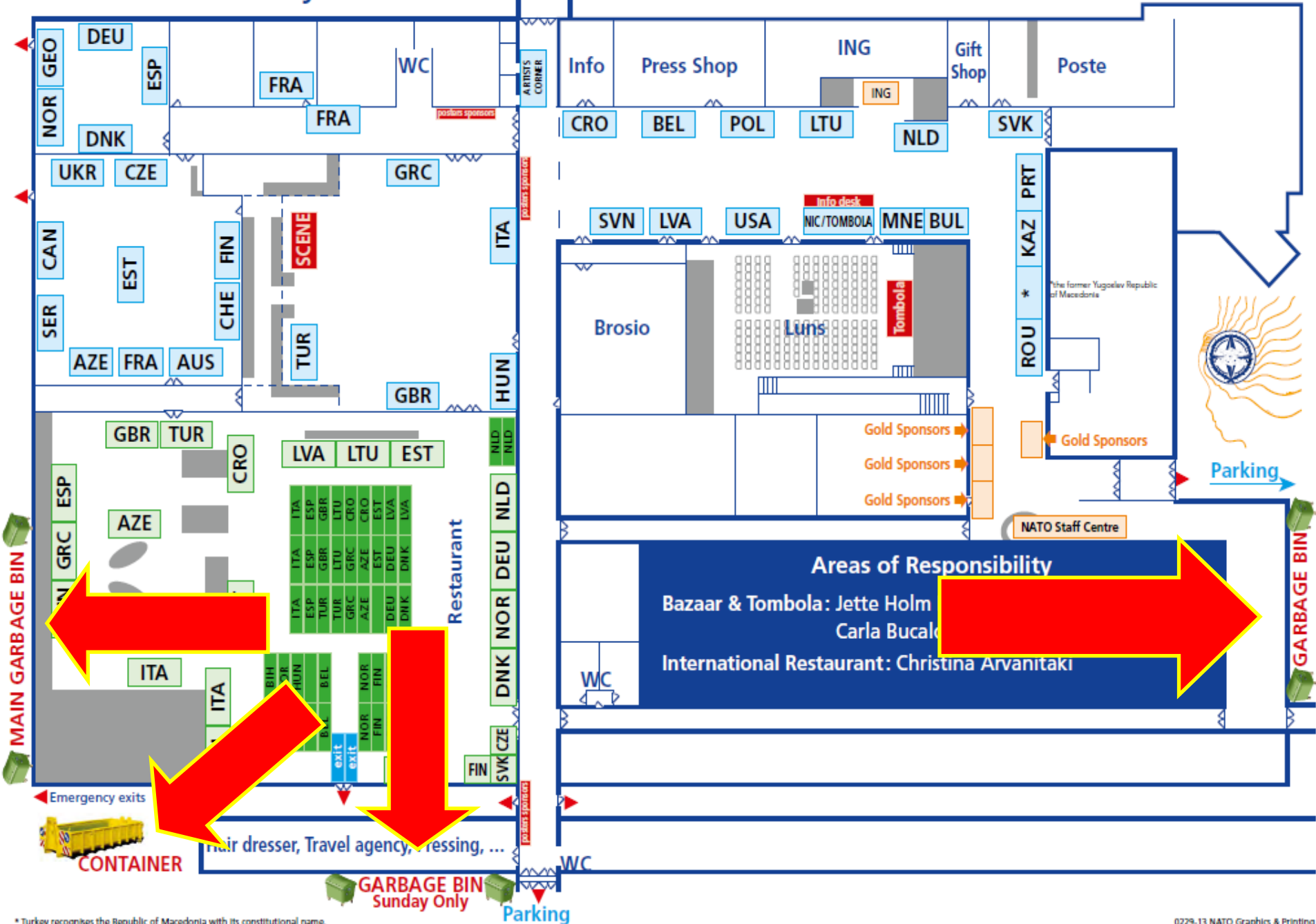

* Turkey recognises the Republic of Macedonia with its constitutional name.



GARBAGE MANAGEMENT inside Bazaar

CLEAN UP:

We are responsible of the garbage bins closest to our stands.

Empty yellow garbage pails hourly – or before if needed. Replace the white bag with a new one.

Throw filled white garbage bags in appropriate bins/container ONLY (outside behind kitchen.





Keeping the Bazaar Clean

MONITOR TRASH – EMPTY OFTEN





NATO Charity Bazaar 2013 > Clean-Up Check List <



NATION: _____

NATIONAL STANDS

- Dismantle and/or stack tables in designated area. _____ Number of tables
- Return Name Plates to NCB Information Desk in front of the Luns theatre
- Take all garbage to designated garbage dumpsters
 - o Empty white bags from yellow garbage cans into **red bins** or the big container.
 - o Dispose of paper and cardboard boxes in **blue bins**.
- Sweep and/or vacuum floor (please bring a broom, dustpan and vacuum).
- Wait for sign off below from NCB Board Member before leaving for the day.

NCB Board Member Sign Off

KITCHEN & RESTAURANT STANDS

- Clean cooking area
- Return all borrowed cooking utensils
- Return Name Plate and flags to NCB Information Desk in front of the Luns theatre.
- Clear and clean tables used for your stand with wet towels or sponges.
- Clear and clean restaurant tables with wet towels or sponges.
- Garbage (dumpsters outside behind kitchen)
 - o Empty bags from yellow garbage cans in **red bins** or in the big container.
 - o Dispose of paper and cardboard boxes in **blue bins**.
 - o Put glass in appropriate boxes.
- Sweep floor around your tables (please bring a broom and dustpan).
- Wait for sign off below from NCB Board Member before leaving for the day.

NCB Board Member Sign Off

NATO Charity Bazaar 2013
> Clean-Up Check List <



NATION: YOUR COUNTRY

NATIONAL STANDS

- ✓ Dismantle and/or stack tables in designated area. # Number of tables
- ✓ Return Name Plates to NCB Information Desk in front of the Luns theatre
- ✓ Take all garbage to designated garbage dumpsters
 - Empty white bags from yellow garbage cans into **red bins** or the big container.
 - Dispose of paper and cardboard boxes in **blue bins**.
- ✓ Sweep and/or vacuum floor (please bring a broom, dustpan and vacuum).
- ✓ Wait for sign off below from NCB Board Member before leaving for the day.

SIGNATURE

NCB Board Member Sign Off

KITCHEN

- Clean cooking area
- Return all borrowed cooking utensils
- Return Name Plate and flags to INFO table
- Clear and clean tables used for your stand with wet towels or sponges.
- Clear and clean restaurant tables with wet towels or sponges.
- Garbage (dumpsters behind kitchen)
 - Empty bags from yellow garbage cans in Red bins.
 - Dispose of paper and cardboard boxes in Blue bins.
 - Put glass in appropriate boxes
- Sweep floor around your tables (please bring a broom and dustpan).
- Wait for sign off below from NCB Board Member before leaving for the day.

SIGNATURE

NCB Board Member Sign Off

CLEAN UP



ALL TABLES
need to be
stacked unless
they are
permanent
tables for the
room.

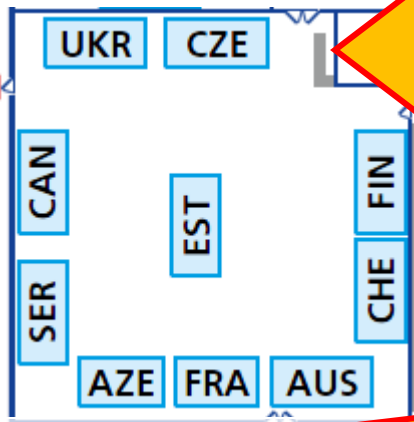

CLEAN UP

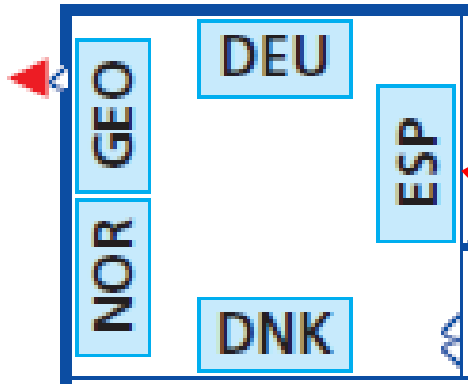

Most tables stay in the room unless they were extras that needed to have legs attached.

CLEAN UP

Legs need to be removed from the tables and stacked on pallets

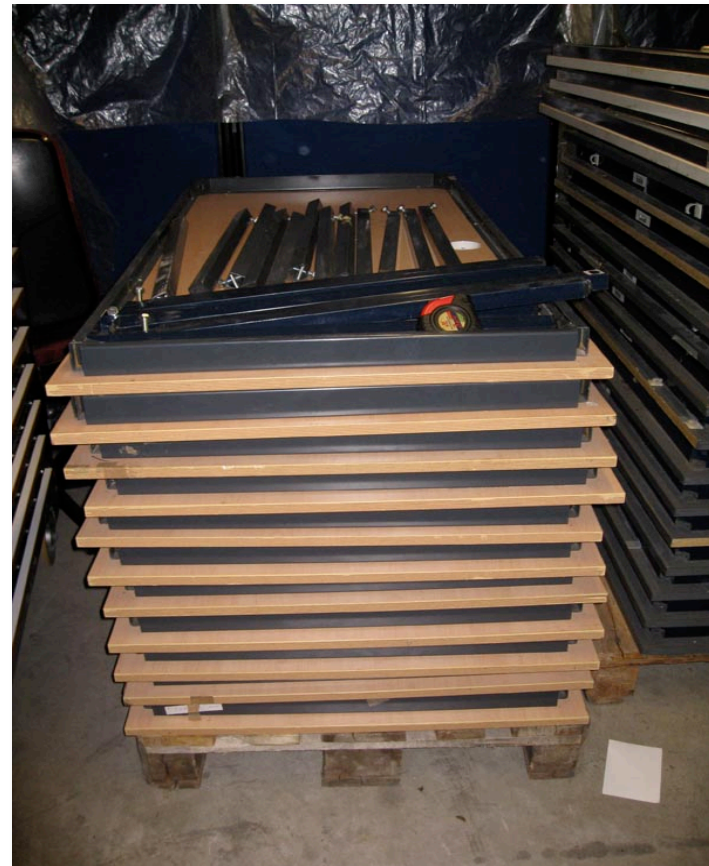
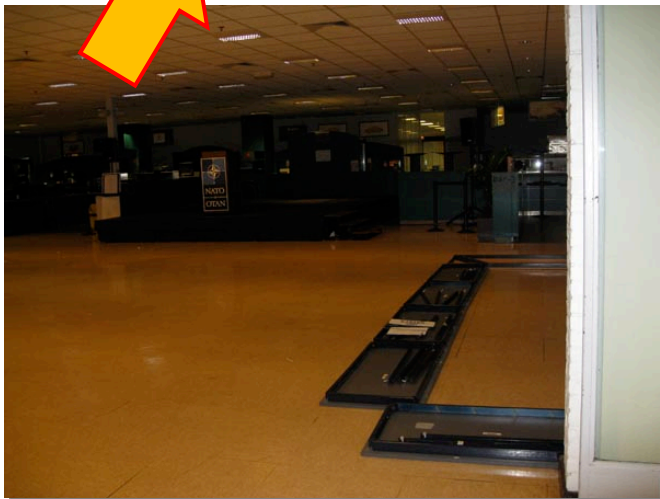
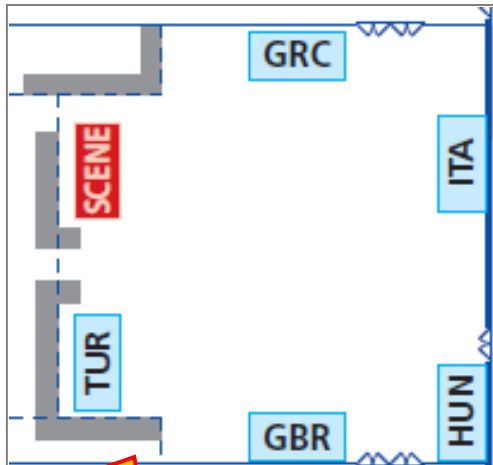

CLEAN UP

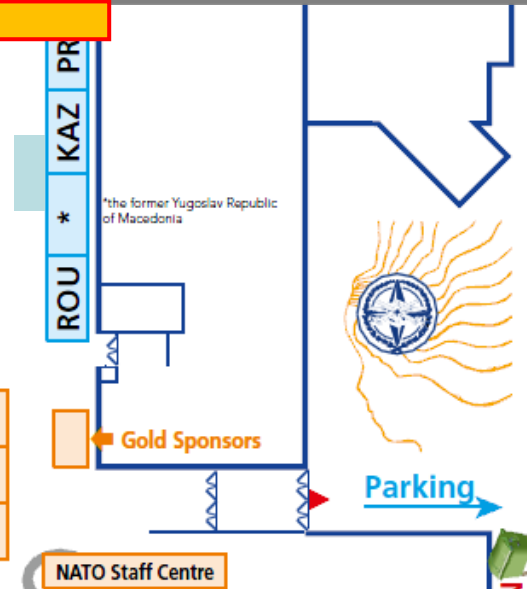
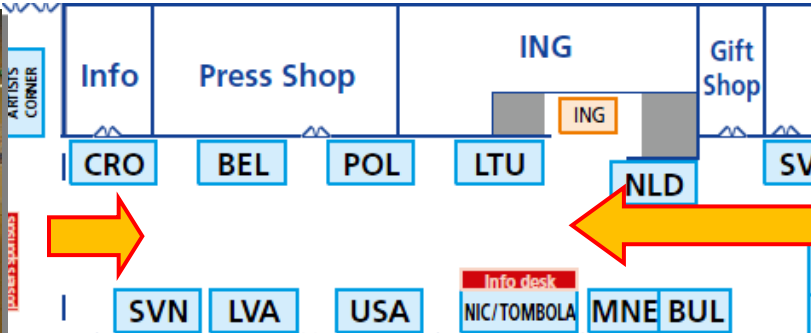

Tables need to be folded and placed on carts.

USA tables need to be pushed against the wall.

**SHARE THIS INFORMATION
WITH YOUR TEAM**





Thanking NATO Staff

#1



Sign on the back for:
1 x Food (main dish),
1 x Dessert, 1 x Drink

NATO Charity Bazaar

www.natocharitybazaar.org

— ASBL —

#2

Thank You Gift

1 Bottle per Nation

DUE: 22 OCT GA Meeting

If you have not provided your bottle, bring it to our 'Info Desk' Saturday, 16th November



NATO Staff FOOD VOUCHER

1 x Main Dish

1 x Dessert

1 x Drink



Opening Ceremony

Jimmie Bradshaw – President

09:00 Dignitaries and sponsors arrive and go to Cafeteria for 'Patrons & Sponsor Welcome Coffee' and Photo Session

09:10 Members arrive at stage area

09:30 Photos with Dignitaries and Members

09:45 Opening Ceremony

- Remarks

- Mrs. Rasmussen
- Chairman of the Military Committee, General Knud Bartels
- NCB Honorary President, Lady Jan Harper

- Roll Call of Participating Nations

- Ribbon Cutting

The Bazaar is declared officially opened.

10:15 International Restaurant preview

11.00 National Stands preview

Roll Call of Participating Nations

Honorary President, Lady Jan Harper, and Honorary Vice-President, Ms. Kati Schmidt will alternate calling the role of participating nations and clubs, who will then take a step forward and answer *Present* in their own language.





Ribbon Cutting

After the Ribbon Cutting the Bazaar is declared officially opened.

10:15 International Restaurant preview

11:00 National Stands preview



Bazaar After Sale

Dates: Nov 18 - 22 | Monday - Friday

Time: 10:00 – 14:00

Location: Press Hall (ING Bank Area)

Participants: 5 nations per day (only 3 on Tuesday)

Mon 18 Nov	Tues 19 Nov	Wed 20 Nov	Thu 21 Nov	Fri 22 Nov
1. Italy 2. Poland 3. Spain 4. Belgium 5.	1. Italy 2. Greece 3.	1. USA 2. Latvia 3. Greece 4. 5.	1. Hungary 2. Azerbaijan 3. Portugal 4. Estonia 5.	1. Lithuania 2. 3. 4. 5.

Each nation gets 2-3 tables
Everyone needs to be self sufficient



Tombola Instructions

Carla Bucalossi Quatrini - Tombola Coordinator

- **Final instructions**
 - Ticket Sales Schedule
 - Turning in tickets
 - Saturday & Sunday Instructions
 - What to do with Prizes + stubs of sold tickets and unsold tickets
 - Members drawing and Tombola Winners
 - Picking up Prizes

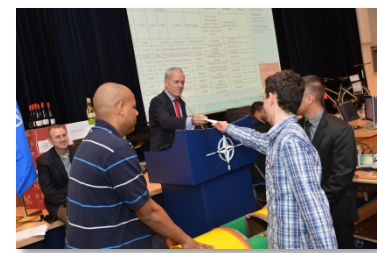

NATO Charity Bazaar

NATO CHARITY BAZAAR - Tombola Ticket Sales

as of 11 November 2013

OCTOBER – OCTOBRE OCTOBER – OCTOBRE OCTOBER – OCTOBRE				
	1000-1200	1200-1400	1400-1600	NOTES
TUE, 1 OCT	USA	Italy	Lithuania	
WED, 2 OCT		Slovakia	Slovakia	
THU, 3 OCT	Hungary	FYR of Macedonia		
FRI, 4 OCT	Czech Republic	Georgia		
MON, 7 OCT		Serbia		
TUE, 8 OCT		Croatia		
WED, 9 OCT	Poland	France		
THU, 10 OCT	Netherlands	Norway		
FRI, 11 OCT	Hungary	Germany	Montenegro	
MON, 14 OCT	Azerbaijan			
TUE, 15 OCT		UK	Italy	
WED, 16 OCT			Greece	
THU, 17 OCT	Slovenia	Portugal		
FRI, 18 OCT			Ukraine	

Ticket Sales Schedule 2013

NATO CHARITY BAZAAR - Tombola Ticket Sales

as of 11 November 2013

NOVEMBER – NOVEMBRE NOVEMBER – NOVEMBRE NOVEMBER - NOVEMBRE				
	1000-1000	1200-1400	1400-1600	NOTES
MON, 4 NOV		Hungary	Spain	
TUE, 5 NOV		Romania		
WED, 6 NOV		Usa		
THU, 7 NOV	Latvia	Latvia	Estonia	
FRI, 8 NOV		Finland		
MON, 11 NOV	Bulgaria	Belgium		
TUE, 12 NOV		Canada		

Updated schedule always available in **‘Members Only’** area on NCB Website

NATO Charity Bazaar

Floor Plan 2012

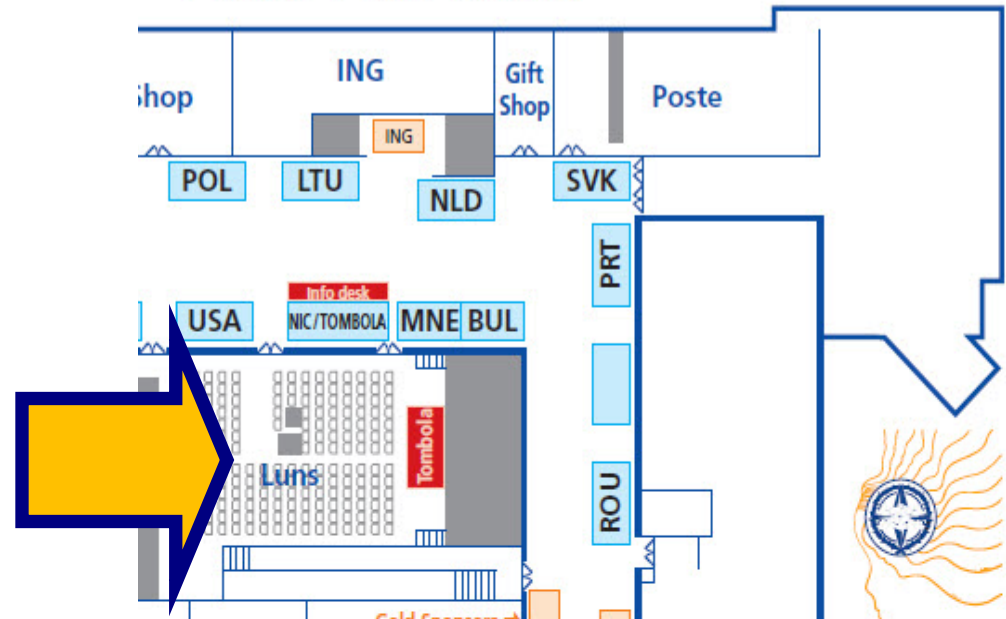

BRING

- Prizes to Luns Theatre on Saturday Between 9-11am
- Unsold tickets, Ticket Stubs of sold tickets + Accountability Sheet

Tombola Instructions

SATURDAY



TURNING IN PRIZES

- Turn in prizes between 9-11am **along back wall** of Luns Theatre.
- **All prizes need to be wrapped (preferably in cellophane) and ready for display.**
- Prizes will be available for viewing beginning Saturday afternoon.

TURNING IN TICKETS

- Bring unsold and stubs of sold tickets AND Accountability Sheet to **the front** of the Luns Theatre between 9-11am

Tombola Instructions

SUNDAY



- **TICKET SALES:** Tombola Tickets available for sale at NCB Info Desk in front of the Luns Theatre from 9:00am – 13:00 (1:00pm)
- **BEGINS:** Tombola begins at 14:00 (2:00pm)
- **ENDS:** Tombola ends at 16:00 (4:00pm)
- **WINNERS:** Winning ticket numbers will be displayed on the big screen

IMPORTANT

Members Draw Tombola Winners



- **Drawing begins at 14:00 (2.00pm)**
- **Every nation can send one or more representatives to draw their prizes.**
- **We will go in alphabetical order. If you are not present when your nation is called, we will call someone from the audience.**
- **The Dignitaries will be the first group to draw.**

PICKING UP PRIZES

PICK UP: Tombola Prizes will be available for pick up during the Bazaar.

LIST OF WINNERS: Winning numbers will be posted on Minerva and on Posters beginning Tuesday, November 19th

AFTER BAZAAR: Tombola Winner Prizes available at NATO HQ during After Sale.





Coffee Break

15 min



NATO Charity Bazaar

www.natocharitybazaar.org

— ASBL —



International Restaurant 2013

Christina Arvanitaki - Restaurant Coordinator



Reminders



NATO Charity Bazaar

www.natocharitybazaar.org

— ASBL —



International Restaurant 2013

Christina Arvanitaki – Int. Restaurant Coordinator

Nations selling on Saturday

1. Belgium
2. Bosnia & Herzegovina
3. Czech Republic
4. Denmark
5. Estonia
6. Germany
7. Greece
8. Italy
9. Latvia
10. Lithuania
11. The Netherlands
12. Portugal
13. Slovakia
14. Turkey
15. United Kingdom

NATO Charity Bazaar



Restaurant Floor Plan 2013

Christina Arvanitaki - International Restaurant Coordinator



Table Size: 70 x 80 cm
3-5 tables per row

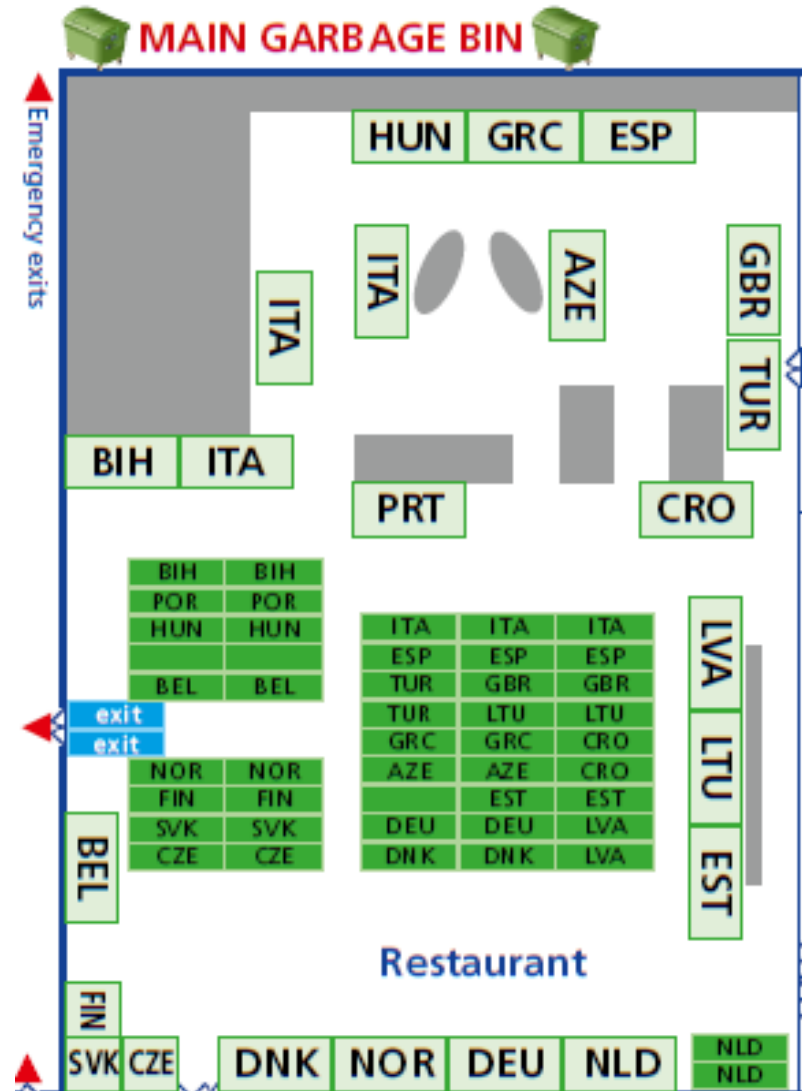

BAZAAR SETUP IN RESTAURANT ON SATURDAY

- **Set Up:** Begins at 8:00h
- Decorating the Tables in the Dining Area
- Placing your nation's Name Plate
- Checking Helper and Delivery Passes
- Checking Electricity Outlets
- **15** nations selling food and drink on Saturday
- Don't forget to clean up!
- Shop, eat and enjoy the day!
- **Closing on Saturday:** 14:00h

**Be sure you leave everything
clean and ready for **Sunday** 😊**

When you arrive on Saturday



You will have:

- Tables labeled with flags + chairs
- Fridges/Shelves labeled with flags
- Your Country Name Plates
- Two (2) white garbage bags
- Clean Up Check List + Floor Plan
- Phone Card (**Key Contact Numbers**)





Keeping the Tables Clean MONITOR TRASH – EMPTY OFTEN

12 volunteered Teen Helpers

NATO Charity Bazaar

www.natocharitybazaar.org

— ASBL —



How it looks during 'Rush Hour'





International Restaurant 2013

Christina Arvanitaki – Int. Restaurant Coordinator

VOLUNTEERED TEEN HELPER'S

1. Ms. Ida Gahner Holm - **DNK**
2. Ms. Ira Lozar Zajec - **SLV**
3. Mr. Daniel Gahner Holm - **DNK**
4. Ms. Adamantia Aimilia Dimitrakopoulou - Lydia - **GRC**
5. Ms. Sophie Summer Beech - **UK**
6. Ms. Isabella Cunningham - **UK**
7. Mr. Edgar Bucens - **LVA**
8. Ms. Margherita Andriulli - **ITA**
9. Ms. Camilla Cioli - **ITA**
10. Mr. Giulio Iaione - **ITA**
11. Ms. Polytimi Papadimitropoulou - **GRC**
12. Ms. Greta Petazzoni - **ITA**



NATO Charity Bazaar



CHILDREN IN THE KITCHEN AREA

For security reasons *children under the age of sixteen (16) years are NOT allowed in the kitchen area!*



NO EXCEPTIONS !



Donating Leftover Food

Pick Up at 16:30h



[More info](#)

For all volunteers who wishes to be registered for the New Year's Eve

[More info](#)

Menu

► [Version française](#)

► [Nederlandse versie](#)

► [Shoe-box.be](#)

► [Our Actions](#)

► [Our volunteers](#)

► [Our donors](#)

► [Useful addresses](#)

► [Press-Media](#)

► [Megaphone](#)

► [Collect points](#)

► [Photos gallery](#)

Contact

The Samaritans Not-for-profit Org.

Chaussée de Haecht 1016
1140 Brussels

+32 (0)472 330 330

+32 (0)2 243 08 48

info@the-samaritans.org

The Samaritans

The organization "The Samaritans" is an not-for-profit organization under Belgian law. "The Samaritans" asbl was created in 1994 by Mr. Claude Vander Elst. The main purpose of the organization is to provide assistance to the homeless and other needy people in Brussels through a weekly distribution of soup and sandwiches in the corridor of Central Station.



At the same time, we try to provide blankets, and sleeping bags, especially to those sleeping in the street. All of this is dependent on the donations that we receive.

The distribution takes places weekly on Tuesday evening at 19:30 in the corridor that connects Central Station with the Brussels metro.

A restaurant provides us the whole year long with soup, our volunteers take care of the sandwiches, and several bakeries provide bread and pastries.

Apart from this main activity, we organize every year, on the evening of December 31, a festive New Year's Eve dinner, including a starter, a main dish, and a dessert. The whole meal is accompanied by soft drinks. Finally, the event is concluded with a present for every participant. Every year, more than 350 people take part in this event, including many children.

We find it important to mention that our organization definitely does not want to judge anybody, whether talking about a person's past, present, or future. Our organization does not spread any political nor religious ideology. Our only goal is to help people in need, whoever they are and wherever they come from.

FINAL INTERNATIONAL RESTAURANT COORDINATION MEETING



**14th November 2013 at 15.00h in NATO Self
Service Restaurant with Chef**



Invitations & Lists

Guest Coordinator - Beckie Metelko

guest-coordinator@natocharitybazaar.org

List of Ambassadors attending the Bazaar 2013

Please provide information on any **Ambassadors** coming to the Bazaar, please fill the form below and send it back (by e-mail only) to:

Richard Vaught: guest-coordinator@natocharitybazaar.org
 Jimmie Bradshaw: president@natocharitybazaar.org

If you want to receive your **VIP INVITATIONS** by the **October 22nd** **later than 18 October** to guest-coordinator@natocharitybazaar.org
 The FINAL deadline for **VIP INVITATIONS** is **Monday 28th October 20**

Nation: _____

Title	Surname	First name	Nationality

Please note that Ambassador to NATO do not need to be listed in the above form

For more information please contact:

Richard Vaught, Guest Coordinator: guest-coordinator@natocharitybazaar.org
 Jimmie Bradshaw: president@natocharitybazaar.org

List of Guests attending the Bazaar 2013

Each Nation is allowed a maximum of **6 Invitation/Access Cards for Guests**. The invitations will only admit one person.

Children under 18 will be admitted without invitations but the invitation.

Invitations Cards have to be shown to the Security Guards up

Please fill the form below and send it back (**by e-mail only**) to:
if you want to receive your invitations by the October 22nd General Assembly Meeting, submit this list no later than 18 October to guest-coordinator@natocharitybazaar.org
 The FINAL deadline for Guest Invitation Cards is **Monday 28th October 2013**

After the deadline, remaining Invitation Cards will be distributed

Nation: _____

Nr	Title	Surname	First Name
1.			
2.			
3.			
4.			
5.			
6.			

Please note that Guests will have to park their cars on the Grounds

For more information please contact:
 Richard Vaught, Guest Coordinator: guest-coordinator@natocharitybazaar.org

List Helpers - Bazaar 2013

Please provide the names of the people (maximum 12 per nation) who will be helping you on Saturday and/or Sunday, please fill the form below and send it back (by e-mail only) to guest-coordinator@natocharitybazaar.org

Helpers Cards have to be shown to the Security Guards at the entrance.

If you want to receive your HELPER CARDS by the October 22nd General Assembly Meeting, submit this list no later than 18 October to guest-coordinator@natocharitybazaar.org
 The FINAL deadline for HELPER CARDS is **Monday 28th October 2013**

Please note that access will be given to Helpers through gate Z if they come by car, or through the main gate for pedestrians.

Nation: _____

	Title	Surname	First name	Date of Birth	Nationality	Vehicle type	Plate number
1.							
2.							
3.							
4.							
5.							
6.							
7.							
8.							
9.							
10.							
11.							
12.							

For more information please contact:
 Richard Vaught, Guest Coordinator: guest-coordinator@natocharitybazaar.org



Invitations & Passes

**Guest Cards /- Passes
distributed TODAY**

NATO Charity Bazaar

www.natocharitybazaar.org

— ASBL —



NATO Charity Bazaar

17 November 2013

9h00 – 15h00

Location: NATO Headquarters: Boulevard Leopold III, 1110 Brussels

Bring: Your passes and your Passports

Entrance: Through **Gate Z** only

**File available in
Members Only Area**

FILE NAME:

**Entrance-through-Z-
Gate Map-2013.pdf**

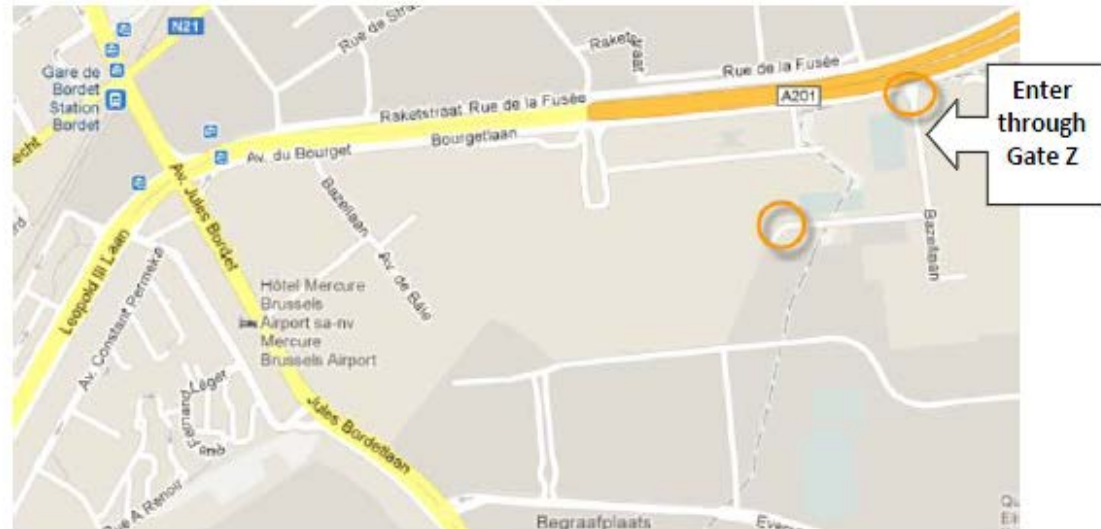



OUR PROUD 2013 SPONSORS

Dionysia Leolei – Sponsor & Event Coordinator

PLATINUM – GOLD – SILVER - BLUE



NATO Charity Bazaar

www.natocharitybazaar.org

— ASBL —



1



NATO Charity Bazaar

www.natocharitybazaar.org

— ASBL —



5

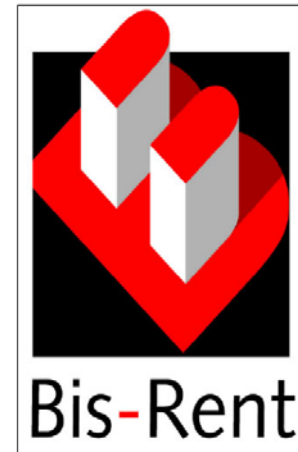

NATO Charity Bazaar



3

1



NATO Charity Bazaar

www.natocharitybazaar.org

— ASBL —



SPONSOR FOR TOMBOLA

Dionysia Leolei – Sponsor & Event Coordinator



Nokia Lumia 720

NATO Charity Bazaar

www.natocharitybazaar.org

— ASBL —



In house donations

- IS Graphics Design and Printing Section (Tombola tickets, Tri-fold, Posters, Food Vouchers, Floor Plan, Farewell Certificates etc.)
- IMS Repro
- NATO Staff
- Stage Equipment from the Swiss Milrep
- Software for updating our website from the Danish Milrep

NATO Charity Bazaar



SPONSORSHIP STATUS 2013

- Amount of money donated by sponsors: 7.750 €
- Amount of goods donated to tombola by sponsors 1.500 €
- In-kind donation from sponsors: 16.500 €
- **Total value of sponsors: 25.750 €**

NATO Charity Bazaar

story time

● Toy donation: we will not accept broken toys, thank you for your understanding
● Story reading and face painting times will be announced on the Staff Centre Stand
(max 10 children per story)

*This year, we will read a super fun new book!
by Julianne Barnett*

Story reading, facepainting, old toy donation
and hot chocolate for chilly winter times!
..at the NATO Staff Centre Stand at the Charity Bazaar!

ages
3 to 9



NSC BAZAAR STAND

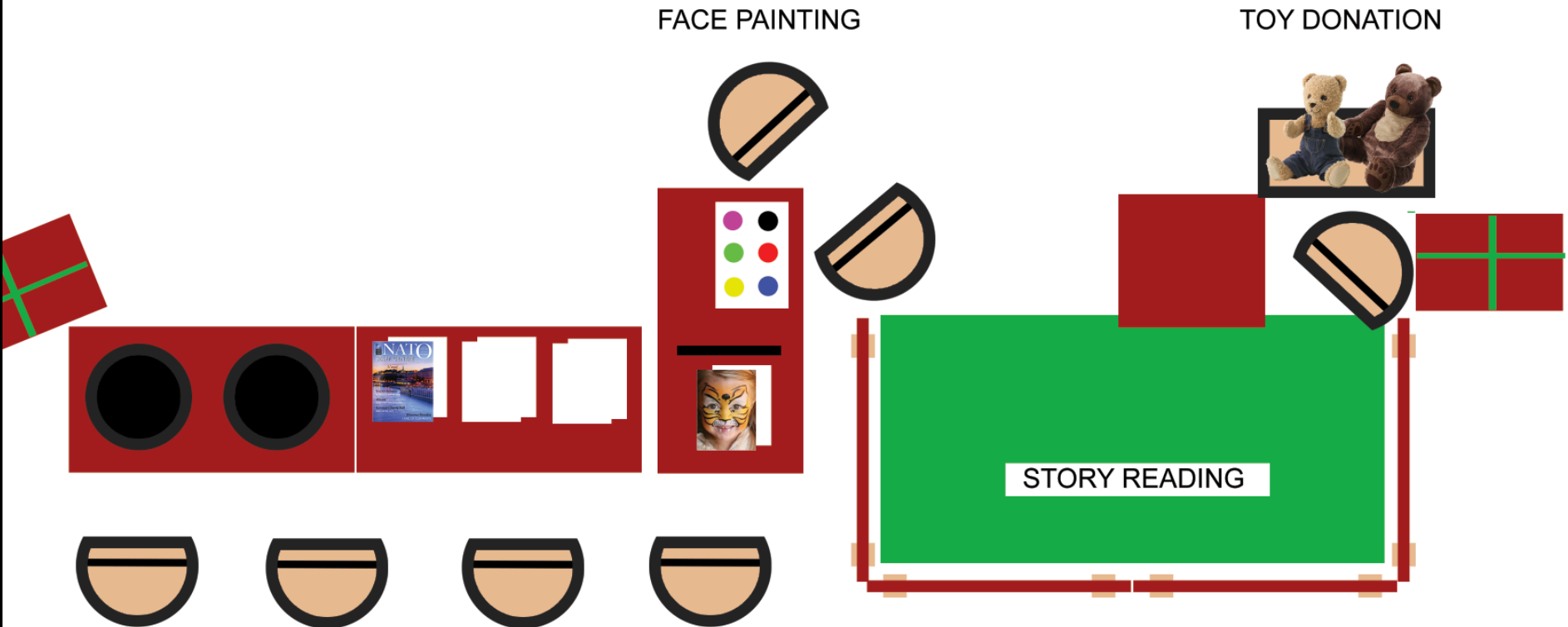

CHRISTMAS FOOD BASKETS SALE

Full of gourmet Mediterranean products

Tuesday 10th of December 2013

11:00-15:30

Grand Chalet - NATO Staff Center

Just behind the pool of NATO Staff Center

EVERYBODY IS WELCOME

Hosted by: *Dionysia Leolei* &

FAB GREECE
gourmet Greek products

www.fabgreece.com

e-mail: sales@fabgreece.com

**TOY DONATION – SUPPORTED BY
NATO STAFF CENTRE & NATO CHARITY BAZAAR**



Treasurer's Report

Alessandra Foresti Bertozzi - Treasurer

- **Treasurer Update**
- **Transfer of funds into the NCB account**

NATO Charity Bazaar

www.natocharitybazaar.org

— ASBL —



Treasurer Update

Alessandra Foresti Bertozzi - Treasurer

TOTAL INCOME 2013

- Sponsor 7.750 €
- Bake Sales 5.957 €
- Out door life 251 €
- Bank premium 20 €



13.978 EUROS

On 10 November 2013

NATO Charity Bazaar

www.natocharitybazaar.org

— ASBL —



Keep in mind

Alessandra Foresti Bertozzi - Treasurer

YOUR GOAL IS :



I have to
remember to make
the transfer
TODAY!!!

Any transfer should be
completed by:
Thursday, 5 Dec. 2013



NATO Charity Bazaar



Treasurer's Report

Alessandra Foresti Bertozzi - Treasurer

If you have any questions regarding this

“Transfer of funds”,

please don't hesitate to contact the Treasurer

Alessandra Foresti, via e-mail at

treasurer@natocharitybazaar.org

or call 0488 416 595



NATO Charity Bazaar



Donation Ceremony

Jimmie Bradshaw – President

27 January 2014

9h30-12h30

NATO Staff Center, Banquet Room

Who may attend:

National Rep. & Assistant National Rep.



NATO Charity Bazaar

www.natocharitybazaar.org

— ASBL —



Fundraising Ideas

Jimmie Bradshaw - President

-
- **Out-Door-Life for Charity 2013 - Status**
with Karen Kiærskou





Any other Business

Jimmie Bradshaw - President

- **New Board Members 2014**
- **Ballroom Fitness 2013**
- **Christmas Charity Ball 2013**

NATO Charity Bazaar

www.natocharitybazaar.org

— ASBL —



Board 2014

Jimmie Bradshaw - President

Available Board Positions in 2014

- Vice-President
- Bazaar Coordinator
- Secretary
- Web Designer /Administrator

NATO Charity Bazaar

www.natocharitybazaar.org

— ASBL —

THIS WINTER
LEARN HOW TO DANCE SOLO
WITH THE PROFESSIONALS

presenting:

BALL ROOM FITNESS

DANCING WITHOUT A PARTNER



FRIDAY, DECEMBER 13, 2013 AT NATO STAFF CENTRE
VENDREDI, 13 DECEMBRE 2013
AU CENTRE DU PERSONNEL DE L'OTAN

PLEASE BOOK BEFORE SATURDAY, 7 DECEMBER, 2013
VEUILLEZ RESERVER AVANT LE 7 DECEMBRE 2013
TEL: 02 707 4604 - TICKET 5€ P. P.
(NO BOOKING = NO ENTRY, THANK YOU FOR YOUR UNDERSTANDING)
DRESS CODE: SPORT SHOES AND GEAR - HORAIRE/TIME
12H30

*Anne-Mette Rasmussen
Thomas Ewert Poulsen*

 NATO
STAFF CENTRE

profits to charity

December 13th at 12h30 – NATO Staff Centre

ALL PROFITS TOWARDS CHARITIES IN AFGHANISTAN
BENEFICES EN FAVEUR DES OEUVRES CARITATIVES EN AFGHANISTAN

Charity Ball

DINNER, WONDERFUL DANCE
SHOW, LIVE ORCHESTRA & TOMBOLA

DINER, MERVEILLEUX SPECTACLE
DE DANSES, ORCHESTRE & TOMBOLA

DECEMBER 14 AT 19H30 * 14 DECEMBRE A 19H30
NATO STAFF CENTRE

BOOK AT NATO STAFF CENTRE
RECEPTION - CALL 02 707 4604

GREAT PRIZES
TO WIN

100% worth of prizes!

*and much
more...*



TICKET 50€P.P.

 NATO
STAFF CENTRE

December 14th at 19h30 – NATO Staff Centre



Closing

Jimmie Bradshaw - President

Upcoming Meetings

- **14 November**
 - Final Restaurant Meeting with Chef (Kitchen)
- **12 December**
 - Final 2013 Board Meeting
- **27 January 2014**
 - Donation Ceremony - (NATO Staff Banquet Room)



Please return voting cards and folders

NATO Charity Bazaar

www.natocharitybazaar.org

— ASBL —